

Referans Nr.	L	ı	n	k	e	c	Ø16H7 j	Ø16H7 j1	 (kg)
2470-415K	502	415	-	35	30	31	100	100	33
2470-615K	702	615	-	35	30	31	100	300	42

Ürün Nr. 2470 Divizör Kulesi (Kare)

- Divizör kulesi dik işleme tezgahlarında divizöre bağlanarak, dördüncü eksenini 360 derece kullanma imkanı sağlar.
- Divizör kulesi üzerine iş parçası direk bağlanabildiği gibi, mengene grupları veya farklı aparatlarda kullanılır.
- Siparişte divizör marka model numarasını bildiriniz.
- Yatak merkezi yükseklik için alt plakalar mevcuttur.
- Malzeme : Döküm



Yatak = Nr.2460

Product Nr. 2470 Index Table Turret (Square)

- Index Table Turret is connected to the index table of vertical machining benches and this application provides the possibility to use the fourth axis with 360 degrees.
- Workpiece taking place on the Index Table Turret can be applied directly and at the same time it can be used in vice groups and with different apparatuses.
- Material : Casting

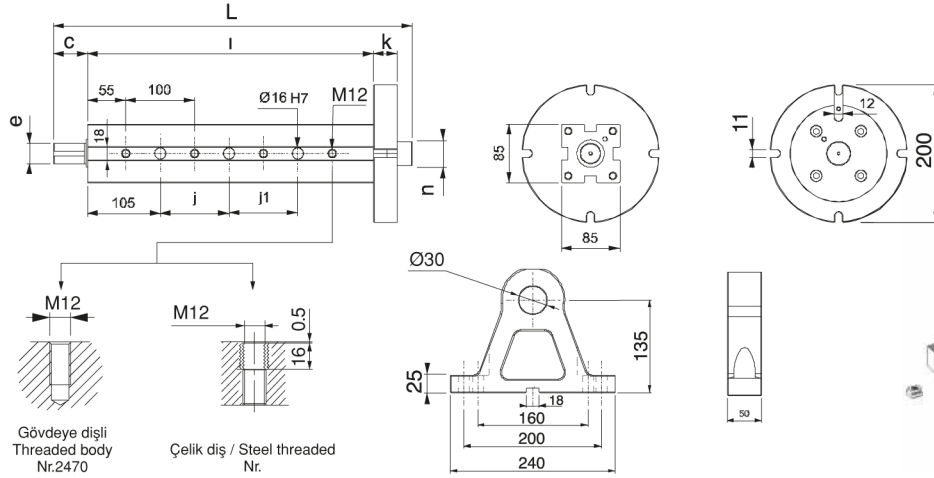

Çift Flanşlı
Nr. 2471

