

Referans Nr.	L	ı	f	n	b	k	c	e	s	Ø16H7 j	Ø16H7 j1	(kg)
2450-415L	503.5	415	45	-	125	35	31	30	72	100	100	29.25
2450-615L	703.5	615	50	-	160	35	31	30	90	100	300	46.75

Ürün Nr. 2450 Divizör Kulesi (Dikdörtgen)

- Divizör kulesi dik işleme tezgahlarında divizöre bağlanarak, dördüncü eksen 360 derece kullanma imkanı sağlar.
- Divizör kulesi üzerine iş parçası direk bağlanabildiği gibi, menzene grupları veya farklı aparatlarda kullanılır.
- Siparişte divizör marka model numarasını bildiriniz.
- Yatak merkezi yükseklik için alt plakalar mevcuttur.
- Malzeme : Döküm

Product Nr. 2450 Index Table Turret (Rectangular)

- Index Table Turret is connected to the index table of vertical machining benches and this application provides the possibility to use the fourth axis in 360 degrees.
- Workpiece taking place on the Index Table Turret can be applied directly and at the same time it can be used in vice groups and with different apparatuses.
- Please, let the dividing brand, model number in the order.
- The lower plate is available for the center height.
- Material : Casting

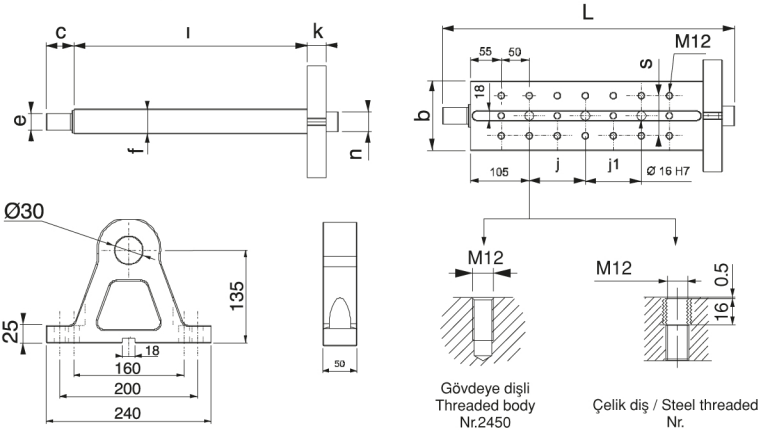

Yatak = Nr.2460

Çift Flanşlı
Nr. 2451

