

Referans Nr.	Çalışma Yağ Basıncı Operating Oil Pressure	Hareket Tipi Acting Type	Strok Stroke	Piston Çubuğu Piston Rod Ø (mm)	Kuvvet Desteği 200kg/ cm ² Supporting Force	Temas Kuvveti / kg Contact force	A	B	C	D	E	F	Ağırlık Weight (kg)
1056-SP16A	100-350 kg/cm ²	Yaylı Spring	8	16	210 kg	-	79	54	8	M30 x1.5	11	8	0.30
1056-SP16B	100-350 kg/cm ²	Hidrolik Hydraulic	8	16	210 kg	2.35	72	54	8	M30 x1.5	11	8	0.30

Ürün Nr. 1056 Hidrolik İş Parçası Desteği

Product Nr. 1056 Hydraulic Work Support



SP16A

SP16B

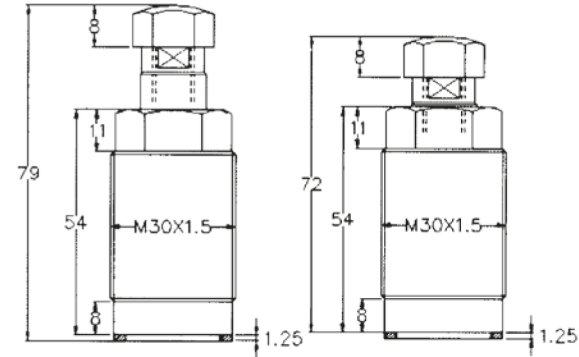

Montaj Detayı / Mounting details

