

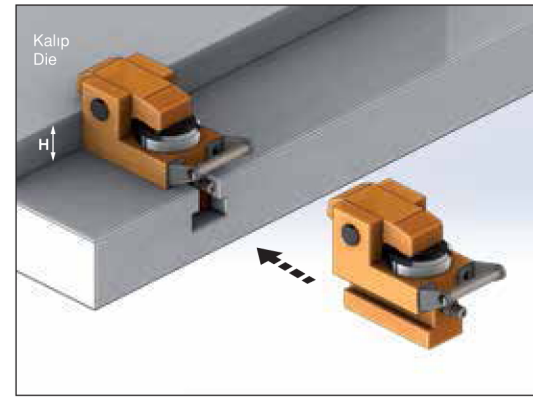

Referans Nr.	L	K	J	H min.	H+d min. max	E min.	F	G	a min.	C min.	P
1015-CB01	74.5	60	14.5	25	100	42	44	20	10	6.5	PT1/8
1015-CB02	110	90	20	25	100	73	68	32	14	10	PT1/4
1015-CB04	134	110	24	25	130	77	79	40	18	12	PT1/4
1015-CB06	159	130	29	30	150	92	96	46	22	14	PT1/4
1015-CB10	189	159	30	40	140	114	117	54	24	16	PT1/4
1015-CB16	230	200	30	40	130	126	129	58	28	20	PT1/4
1015-CB25	265	235	30	45	120	148	156	70	36	23	PT1/4

Model		CB-1	CB-2	CB-4	CB-6	CB-10	CB-16	CB-25
		CBL-1	CBL-2	CBL-4	CBL-6	CBL-10	CBL-16	CBL-25
Bağlama kapasitesi Capacity of clamp	Ton	1	2	4	6	10	16	25
Toplam strok (X) Total stroke (X)	mm	6	8	8	8	8	8	8
Pabuç strok (Y) Stroke of clamp (Y)	mm	2.5	3	3	3	3	3	3
Muhafaza edilen strok (Z) Preserved stroke (Z)	mm	3.5	5	5	5	5	5	5
Silindirin toplam hacmi Total volumn of cylinder	cc	3	7.5	13	21	38	55	98
Kalıp taban kalınlığı toleransı (H) The tolerance of the template thickness (H)	mm	±1.5	±2	±2	±2	±2	±2	±2



**Ürün Nr. 1015 Hidrolik Pabuç Model CB**

- Pabuç ölçüleri (A),(B),(C) ve (D)
- T-Kanala bağlı olarak belirlenir.
- Standart Sıcaklık : 60°
- Hidrolik basınç 250kgf/cm2

**Product Nr. 1015 Hydraulic Clamp Model CB**

- The sizes of clamps(A),(B),(C) and (D) are made based on the size of T-slot.
- Standard Temperature : 60°
- Hydraulic pressure : 250kgf/cm2

- Satın almadan önce T-Kanal (a,b,c,d) ölçüsü ve kalıp tabanı kalınlığını (H) bildiriniz.
- Please indicate the size of T-slot (a,b,c,d) and the thickness (H) of the template for the die when purchasing.

