

DLP

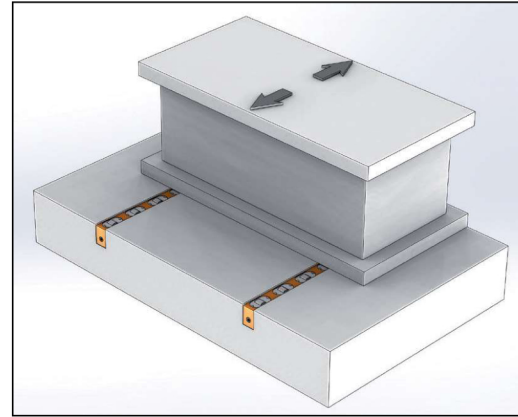

DBP

Dış Ölçüler Outline Dimensions	D□□36 Serisi / Serial
Pleyt için işlem ölçüsü (U-Kanal) Processing Size for Plate (U-slot)	



**Model DLP Hareket Yönü**  
**Model DLP Movement Direction**

Referans Nr.	L	D□□36						
		DLP36 Rulo Roller (DLP)	DBP36 Misket Ball (DBP)	Pnömatik Silindir Pneumatic cylinder				Piston
				6 Bar Kapasite	8 Bar Kapasite	10 Bar Kapasite	12 Bar Kapasite	
1023-0200	200	3	5	200	260	320	400	4
1023-0300	300	5	7	300	390	480	600	6
1023-0400	400	6	10	400	520	640	800	8
1023-0500	500	8	12	550	715	880	1100	11
1023-0600	600	9	15	650	845	1040	1300	13
1023-0700	700	11	17	750	975	1200	1500	15
1023-0800	800	12	20	900	1170	1440	1800	18
1023-0900	900	14	22	1000	1300	1600	2000	20
1023-1000	1000	15	25	1100	1430	1760	2200	22
1023-1100	1100	16	27	1250	1625	2000	2500	25
1023-1200	1200	17	30	1350	1755	2160	2700	27
1023-1300	1300	18	32	1450	1885	2320	2900	29
1023-1400	1400	19	35	1550	2015	2480	3100	31
1023-1500	1500	20	37	1700	2210	2720	3400	34
1023-1600	1600	22	40	1800	2340	2880	3600	36
1023-1700	1700	24	42	1900	2470	3040	3800	38
1023-1800	1800	25	45	2050	2665	3280	4100	41
1023-1900	1900	27	47	2150	2795	3440	4300	43

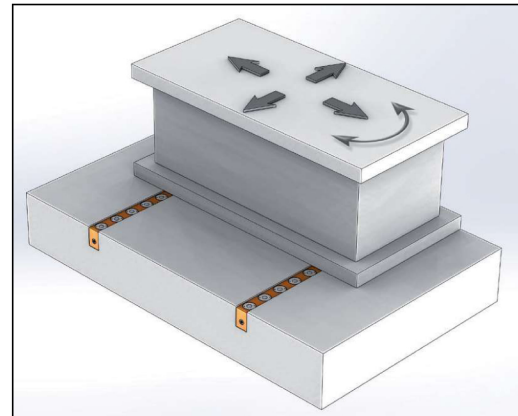

**Model DBP Hareket Yönü**  
**Model DBP Movement Direction**

Ürün Nr. 1023 Hidrolik Kalıp Kaldırma Model DLP-DBP  
• Standart Sıcaklık : 60°

Product Nr. 1023 Die Lifter Hydraulic Model DLP-DBP  
• Standard Temperature : 60°