

Referans Nr.	g	a	L	b	e	(g)
1120-040	M10 M12	14	104	38	38	820
1120-140	M10 M12	14	130	38	38	1030
1130-045	M12 M16	14	130	48	45	1630
1130-145	M12 M16	14	170	48	45	2150
1150-048	M16 M18 M20	18	140	55	48	2070
1150-148	M16 M18 M20	18	200	55	48	3000
1160-059	M20 M22 M24	28	178	74	59	3980
1160-159	M20 M22 M24	28	256	74	59	5800

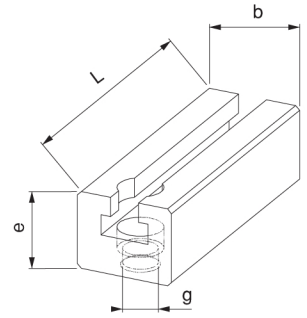

Ürün Nr. 1120-1130-1150-1160

**Alt Destek**

• Sertleştirilmiş

Product Nr. 1120-1130-1150-1160

**Bottom Support**

• Hardened



UYGULAMA;

- 1- Alt desteği iş parçasına uygun şekle getirip sabitle
- 2- K.K.S.P destekler artırılarak istenilen mesafeye ulaşılır
- 3- K.K.S.P imbus civata ile T-Pabuca karşılık T-Kanala tak istenilen pozisyona getir.
- 4- Pabuç imbus civatasıyla iş parçasını sabitle

APPLICATION

- 1- Bottom support is brought to suitable form with the work piece and then it is fixed.
- 2- Desired distance is reached by increasing K.K.S.P supports
- 3- K.K.S.P is applied in T-Slot with imbus bolt against T-Nut
- 4- Work piece is fixed with the imbus bolt of the clamp

