

Referans Nr.	a	m	h		s	s1	e1	d	sw	L	e	b	c	Sıkma Kuvveti Clamping Force Kgf	Nm	g
			min	max												
1150-118 T	18	M16	0	65	18-96	35	125	M20	12	140	43	55	19,5	2500	150	4410
1150-120 T	20	M16	0	65	18-96	35	125	M20	12	140	43	55	19,5	2500	150	4460
1150-122 T	22	M16	0	65	18-96	35	125	M20	12	140	43	55	19,5	2500	150	4515
1150-124 T	24	M16	0	65	18-96	35	125	M20	12	140	43	55	19,5	2500	150	4615
1150-128 T	28	M16	0	65	18-96	35	125	M20	12	140	43	55	19,5	2500	150	4715
1150-118 LT	18	M16	0	65	18-128	35	125	M20	12	200	43	55	19,5	2500	150	5770
1150-120 LT	20	M16	0	65	18-128	35	125	M20	12	200	43	55	19,5	2500	150	5830
1150-122 LT	22	M16	0	65	18-128	35	125	M20	12	200	43	55	19,5	2500	150	5885
1150-124 LT	24	M16	0	65	18-128	35	125	M20	12	200	43	55	19,5	2500	150	5985
1150-128 LT	28	M16	0	65	18-128	35	125	M20	12	200	43	55	19,5	2500	150	6000

Ürün Nr. 1150-(T) Kızaklı Kombine Bağlama Pabucu

- (a) 18-28 T-Kanalda M16 imbus civata DIN 508 T-Pabuçla kullanılır.
- Parça yükseklik sıkma aralığı 0-65mm.
- İleri-geri hareket mesafesi 78mm'dir. Sıkma Kuvveti 2500 kgf.

Ürün Nr. 1150-(LT) Kızaklı Kombine Bağlama Pabucu

- (a) 18-28 T-Kanalda M16 imbus civata DIN 508 T-Pabuçla kullanılır.
- Parça yükseklik sıkma aralığı 0-65mm.
- İleri-geri hareket mesafesi 110mm'dir. Sıkma Kuvveti 2500 kgf.

Product Nr. 1150-(T) Combined Sliding Clamp

- (a) 18-28 is used in T-Slot and M16 imbus bolt is used with DIN 508 T-Nut.
- Height clamping gap of the piece is 0-65mm.
- Back and forth movement distance is 78mm. Clamping force is 2500 kgf.

Product Nr. 1150-(LT) Combined Sliding Clamp

- (a) 18-28 is used in T-Slot and M16 imbus bolt is used with DIN 508 T-Nut.
- Height clamping gap of the piece is 0-65mm
- Back and forth movement. distance is 110mm. Clamping force is 2500 kgf.

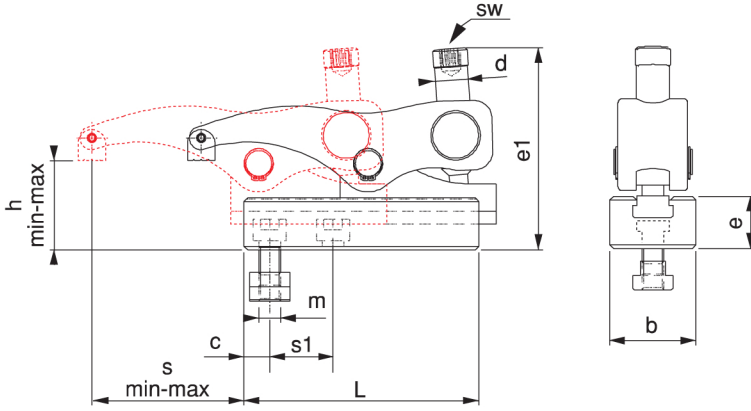

1150-... T



1150-... LT

UYGULAMA;

- 1- Alt kızıağı iş parçasına uygun şekle getir sabitle
- 2- Üst gövdeyi kızıağa sür, istenilen pozisyona getir
- 3- Pabuç imbus civatasıyla iş parçasını sabitle
- 4- Parça işlenmek için hazır

APPLICATION;

- 1- Slide cradle is brought to suitable form with the work piece and then it is fixed
- 2- Upper body is driven to the slide and it is brought to desired position
- 3- Work piece is fixed with the imbus bolt of the clamp
- 4- Then the work piece becomes ready to be machined.

Kullanım Alanı

Enjeksiyon makineleri presler, freze tezgahları, matkap tezgahları ve çeşitli sanayi makineleri

Area of Use

Injection Machines, Presses, Milling Machines, Drilling Machines and various Industrial Machines

