

Referans Nr.	a	H min. - max.	L	ØD	S min. - max.	B	M	 (g)
2377-12512	12	85-125	90	6	30-50	37	M10	780
2377-12514	14	85-125	90	6	30-50	37	M10	780
2377-12516	16	85-125	90	6	30-50	37	M10	780
2377-12518	18	85-125	90	6	30-50	37	M10	780
2377-16512	12	85-165	90	6	50-95	37	M10	865
2377-16514	14	85-165	90	6	50-95	37	M10	865
2377-16516	16	85-165	90	6	50-95	37	M10	865
2377-16518	18	85-165	90	6	50-95	37	M10	865



Ürün Nr. 2377 5D Dayama

- 5 Eksen ayarlama özelliği ile makinalarda ve montaj çalışmalarında hızlı ve esnek şekilde kolay kullanım olanağı sağlar.

Ürün Nr. 2377 5D Pluggable

- With its 5 axis adjustment feature, it provides fast and flexible usage in machines and assembly works.

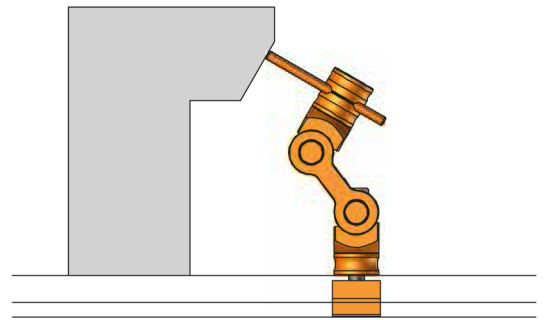
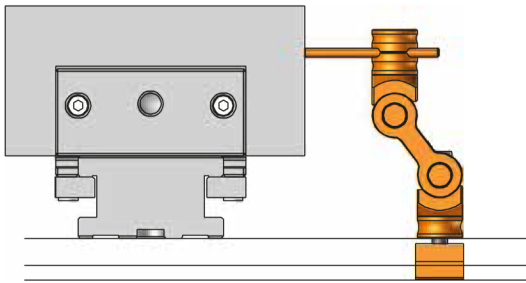
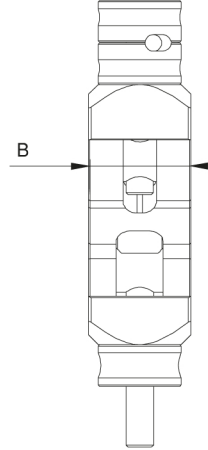
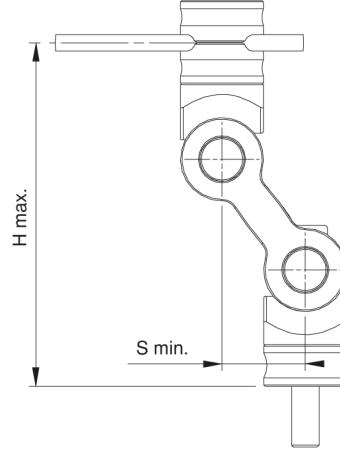
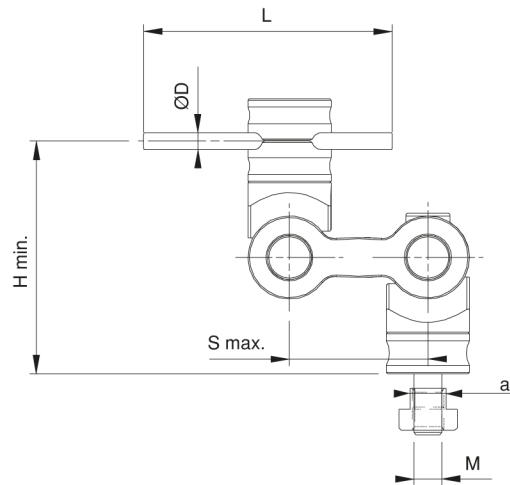

Uygulama Örnekleri / Example Application

