

Referans Nr.	a	m	h		s	s1	e1	d	sw	L	e	b	c	Sıkma Kuvveti Clamping Force Kgf	Nm	g
			min	max												
1120-014 T	14	M12	0	50	12-66	25	100	M14	8	104	35.5	38	13	1600	50	1740
1120-016 T	16	M12	0	50	12-66	25	100	M14	8	104	35.5	38	13	1600	50	1755
1120-018 T	18	M12	0	50	12-66	25	100	M14	8	104	35.5	38	13	1600	50	1785
1120-014 LT	14	M12	0	50	12-81	25	100	M14	8	130	35.5	38	13	1600	50	1980
1120-016 LT	16	M12	0	50	12-81	25	100	M14	8	130	35.5	38	13	1600	50	1995
1120-018 LT	18	M12	0	50	12-81	25	100	M14	8	130	35.5	38	13	1600	50	2000

Ürün Nr. 1120-(T) Kızaklı Kombine Bağlama Pabucu

- (a) 14-18 T-Kanalda M12 imbus civata DIN 508 T-Pabuçla kullanılır.
- Parça yükseklik sıkma aralığı 0-50 mm.
- İleri-geri hareket mesafesi 54mm'dir. Sıkma Kuvveti 1600 kgf.

Ürün Nr. 1120-(LT) Kızaklı Kombine Bağlama Pabucu

- (a) 14-18 T-Kanalda M12 imbus civata DIN 508 T-Pabuçla kullanılır.
- Parça yükseklik sıkma aralığı 0-50 mm.
- İleri-geri hareket mesafesi 69mm'dir. Sıkma Kuvveti 1600 kgf.

Product Nr. 1120-(T) Combined Sliding Clamp

- (a) 14-18 is used in T-Slot and M12 imbus bolt is used with DIN 508 T-Nut.
- Height clamping gap of the piece is 0-50mm
- Back and forth movement distance is 54mm. Clamping force is 1600 kgf.

Product Nr. 1120-(LT) Combined Sliding Clamp

- (a) 14-18 is used in T-Slot and M12 imbus bolt is used with DIN 508 T-Nut.
- Height clamping gap of the piece is 0-50mm
- Back and forth movement distance is 69mm. Clamping force is 1600 kgf.

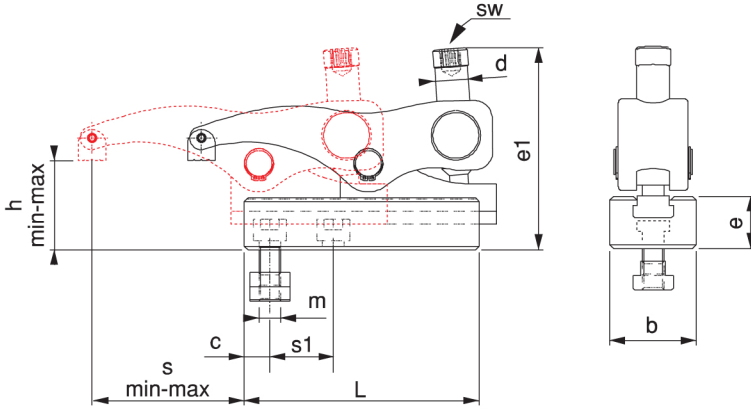

1120-... T



1120-... LT

UYGULAMA;

- 1- Alt kazağı iş parçasına uygun şekilde getir sabitle
- 2- Üst gövdeyi kazağa sür, istenilen pozisyona getir
- 3- Pabuç imbus civatasıyla iş parçasını sabitle
- 4- Parça işlenmek için hazır

APPLICATION;

- 1- Slide cradle is brought to suitable form with the work piece and then it is fixed
- 2- Upper body is driven to the slide and it is brought to desired position
- 3- Work piece is fixed with the imbus bolt of the clamp
- 4- Then the work piece becomes ready to be machined.

Kullanım Alanı

Enjeksiyon makineleri presler, freze tezgahları, matkap tezgahları ve çeşitli sanayi makineleri

Area of Use

Injection Machines, Presses, Milling Machines, Drilling Machines and various Industrial Machines

